

PARTS CATALOG OF  
**TYPE C-1 MACHINE**  
AUTOMATIC FEED



FOOT POWER

**C-E® RIVETING**



ELECTRIC

**EYELETING**

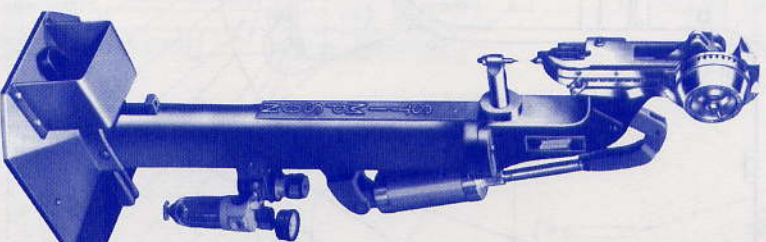

PNEUMATIC

CATALOG  
NO. C-1-93

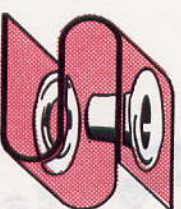

**SISKA inc.**

8 Rosol Lane Ext.  
Saddle Brook, NJ 07663  
201-794-1124

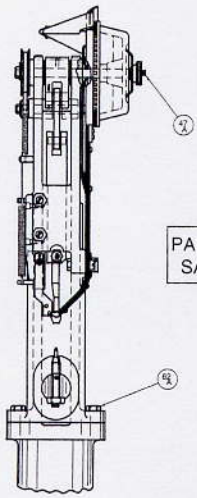

PART NUMBERS NOT SHOWN  
SAME AS POWER MACHINE

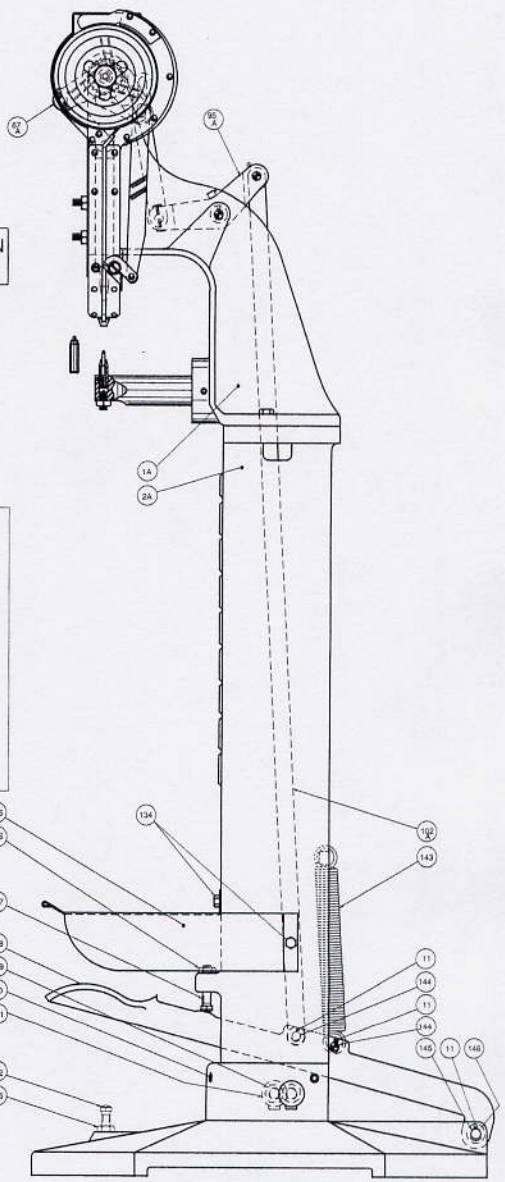
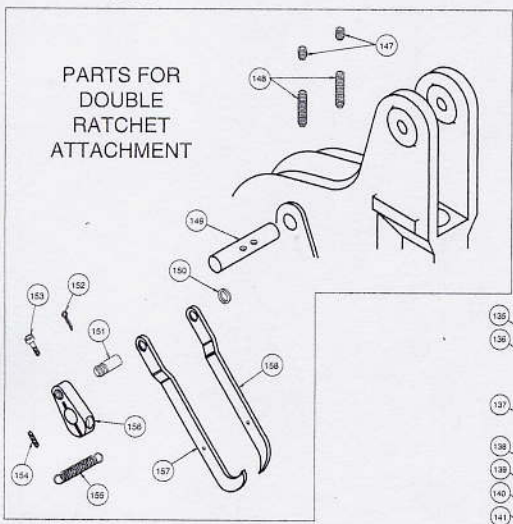



NOTE: SAFETY GUARDS OR OTHER OPERATIONAL SAFETY DEVICES PROVIDED SHOULD NEVER BE REMOVED, DISABLED, OR OVERRIDDEN DURING OPERATION, SINCE THEY ARE DESIGNED TO REDUCE THE POTENTIAL OF INJURY TO OPERATOR.

NOTE: FOR CLUTCH PARTS SEE SUPPLEMENTARY SHEET DETAIL "A" OR "B"

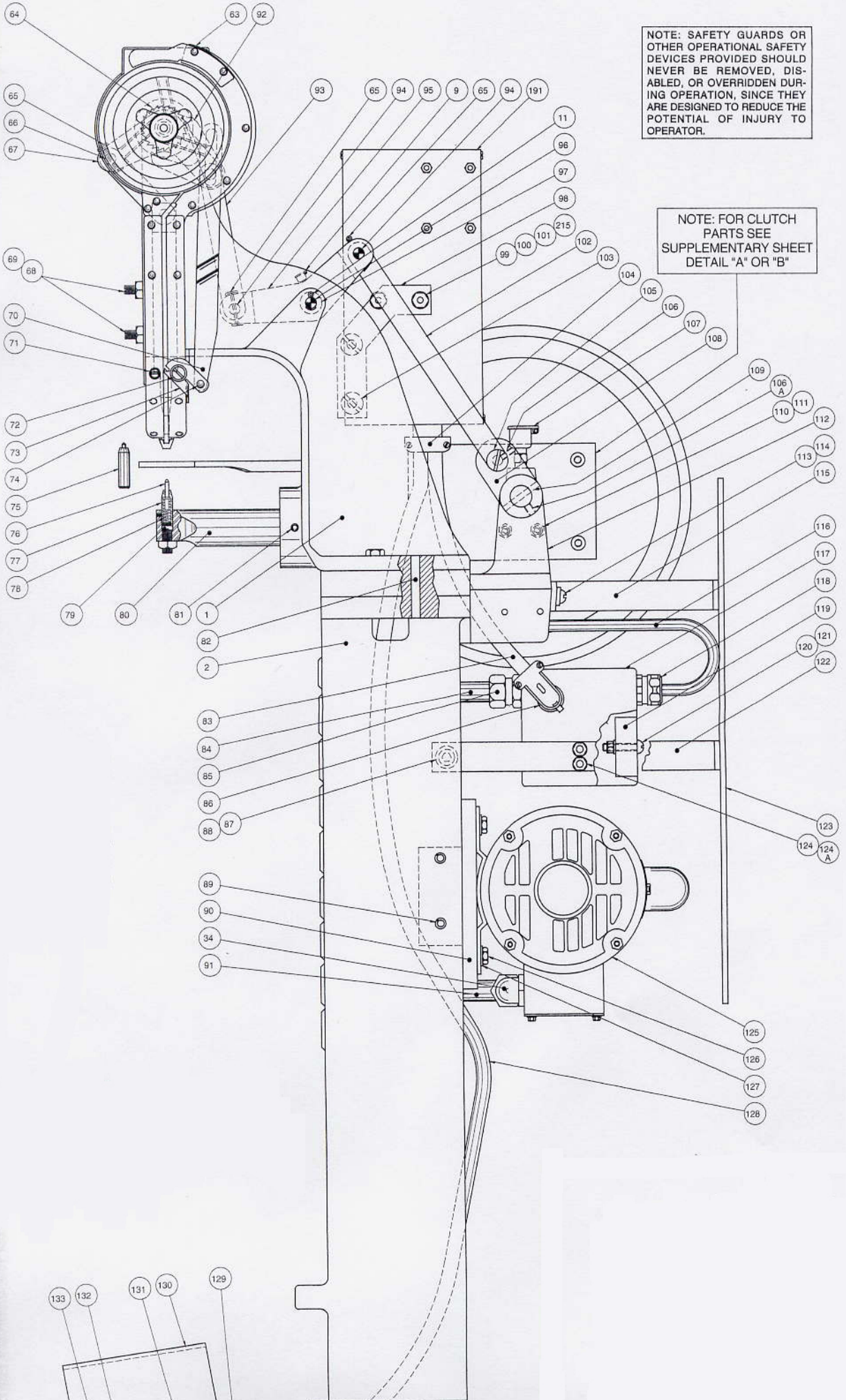

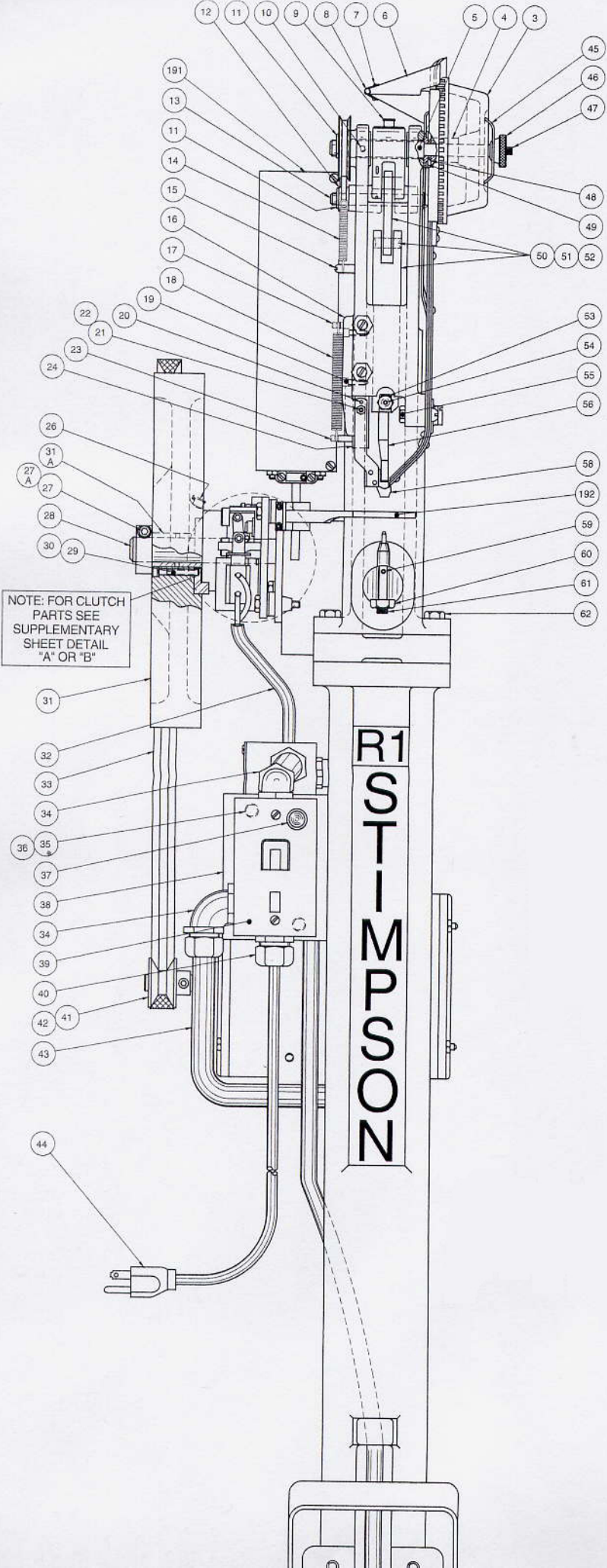

12 11 10 9 8 7 6 5 4 3

45  
46  
47  
48  
49  
50 51 52

191  
13  
11  
14  
15  
16  
17  
18

22 20 19

23 21

24 26

31 A  
27 A

27 28

30 29

53  
54  
55  
56  
58  
192  
59  
60  
61  
62

31

32

33

34

36 35

37

38

34

39

40

42 41

43

44



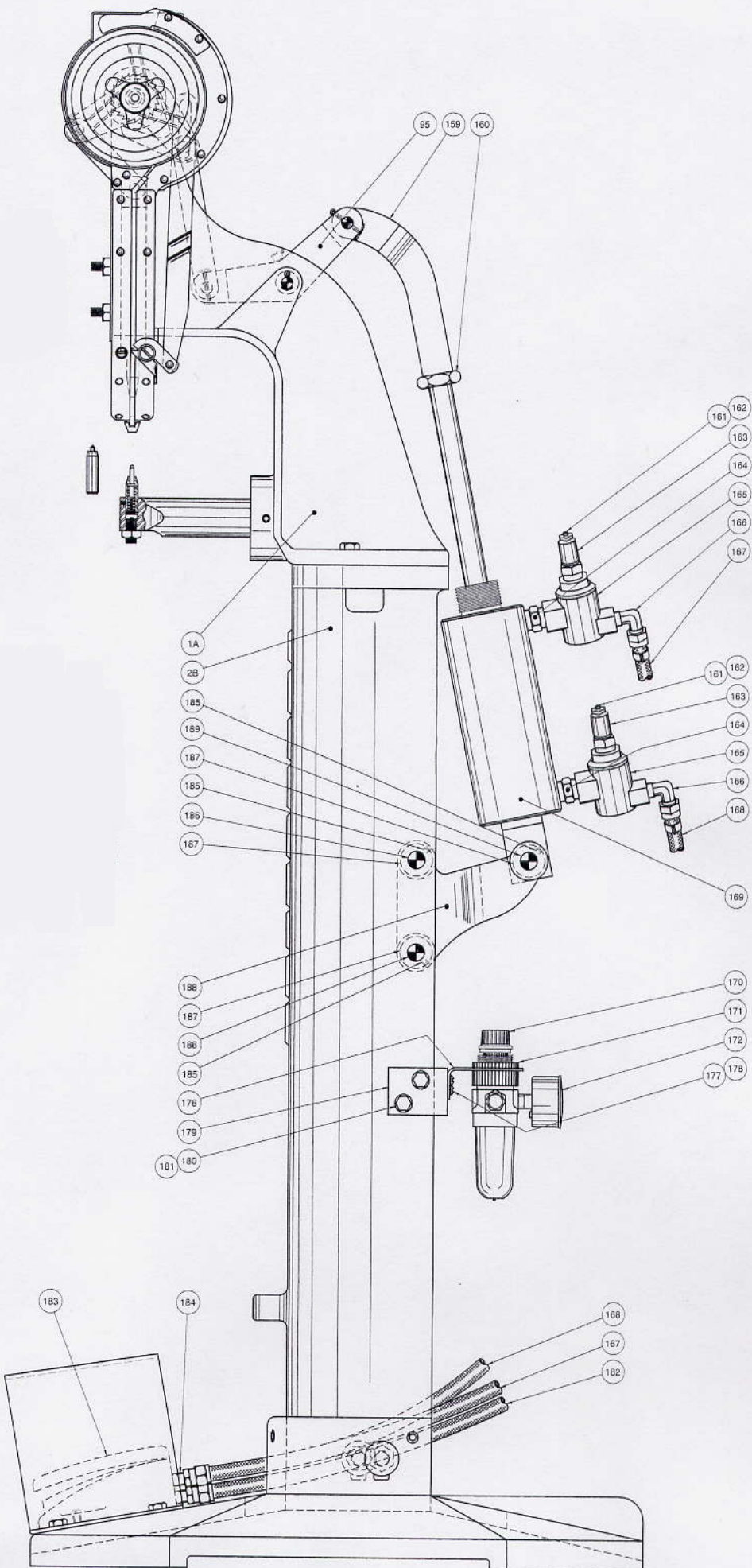

# C-1 PNEUMATIC BENCH MACHINE with ProtectoSwitch

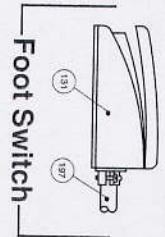
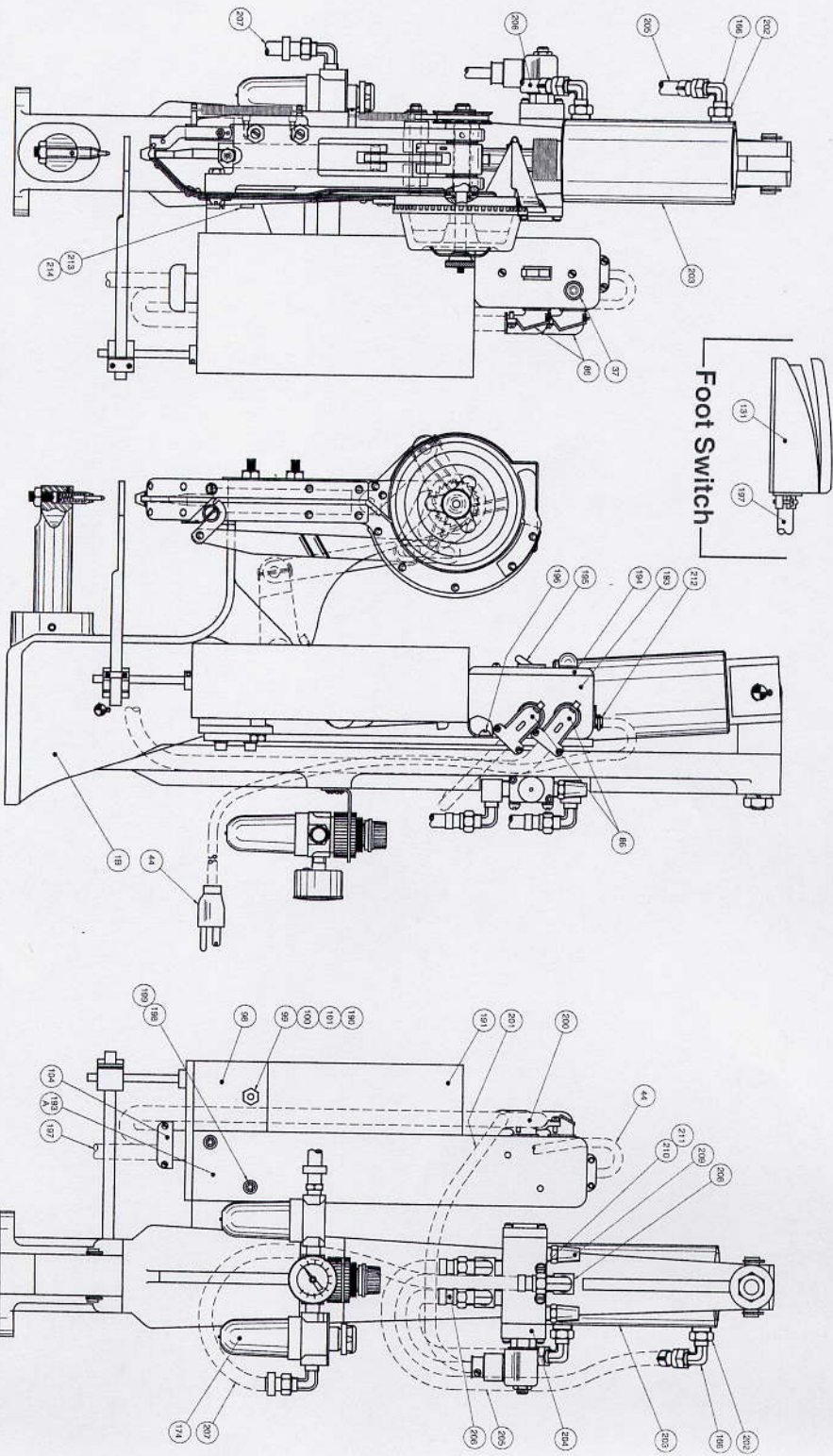

PART NUMBERS NOT SHOWN  
SEE BENCH PNEUMATIC &  
ELECTRIC MACHINE

THIS 4-WAY SOLENOID VALVE SET-UP  
USED WITH PROTECTOSWITCH ON BENCH  
OR STAND PNEUMATIC MACHINE

BACK VIEW





# C-1 PNEUMATIC BENCH MACHINE

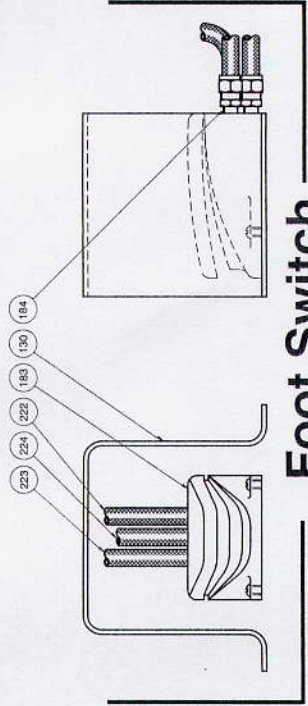
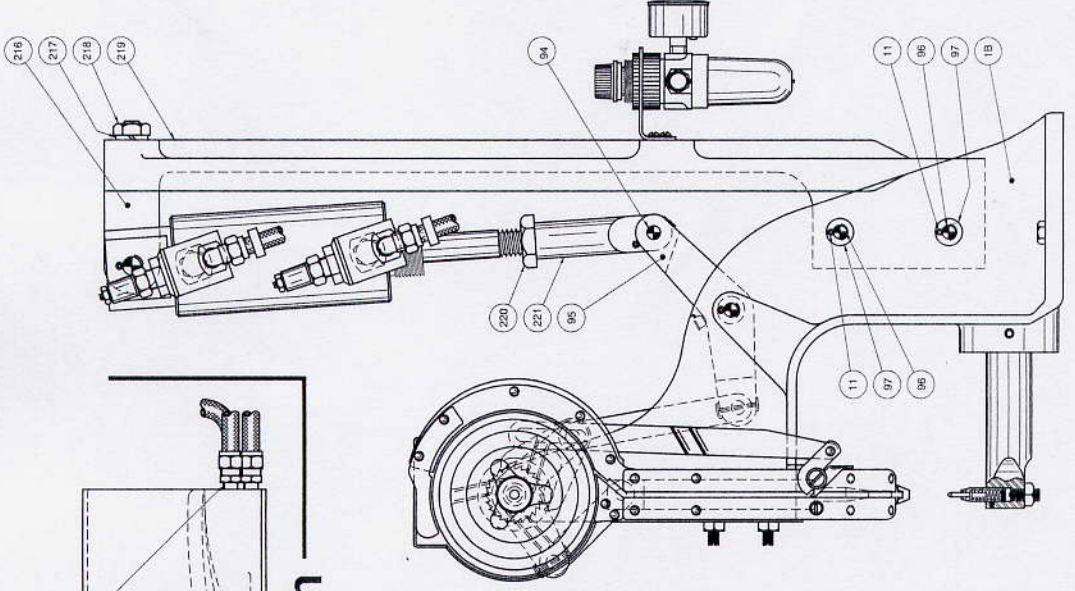

**Foot Switch**

**PART NUMBERS NOT SHOWN  
SEE BENCH PNEUMATIC &  
ELECTRIC MACHINE**

**NOTE: SAFETY GUARDS OR  
OTHER OPERATIONAL SAFETY  
DEVICES PROVIDED SHOULD  
NEVER BE REMOVED, DIS-  
ABLED, OR OVERRIDDEN DURING  
OPERATION, SINCE THEY  
ARE DESIGNED TO REDUCE THE  
POTENTIAL OF INJURY TO  
OPERATOR.**

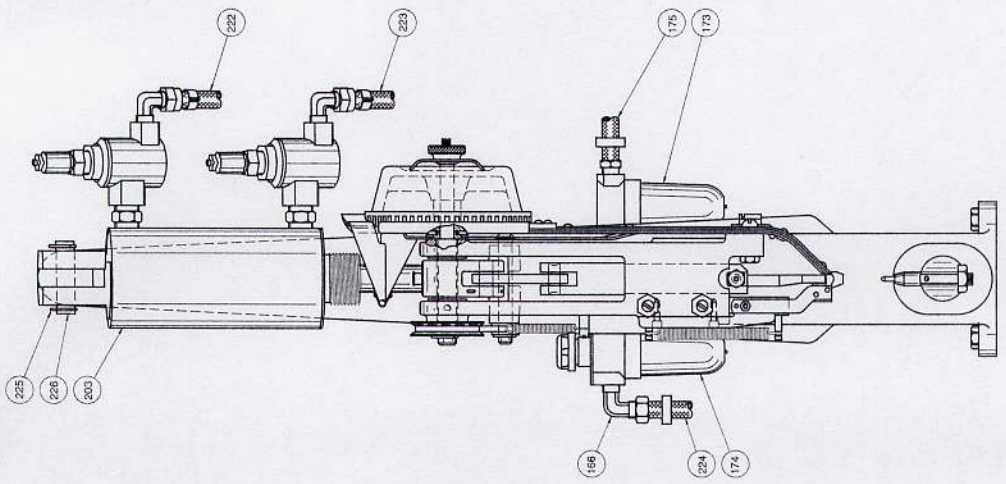



**PARTS FOR STATIONARY POCKETS  
USED ON ALL C-1 EYELET MACHINES**

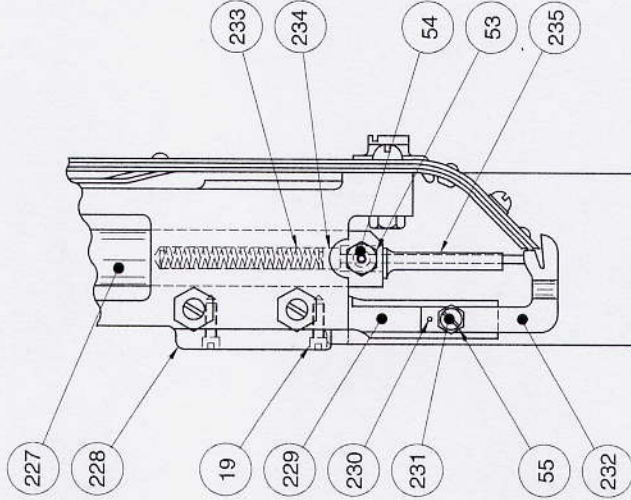

**PARTS FOR SPINDLE STOP ATTACHMENTS  
USED ON C-1 EYELET MACHINES**

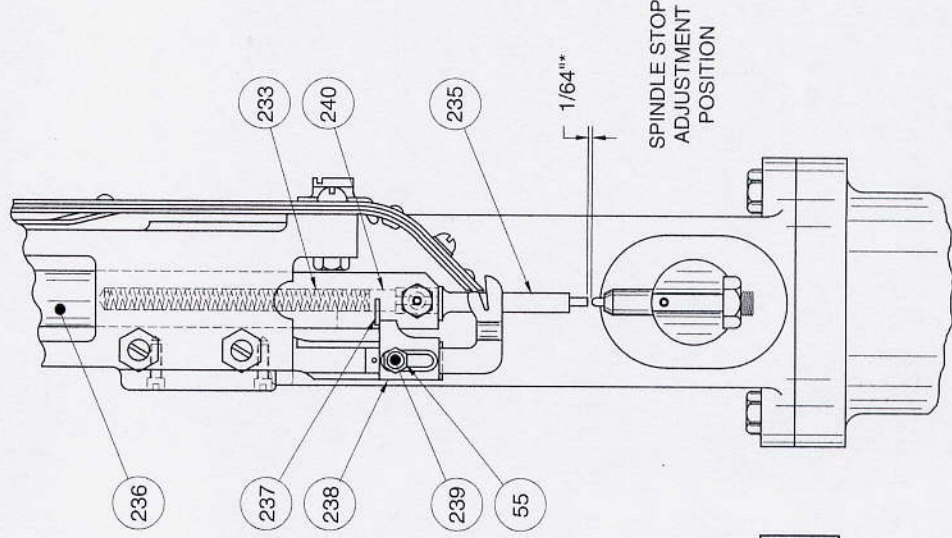

PART NUMBERS NOT SHOWN  
SEE ELECTRIC MACHINE

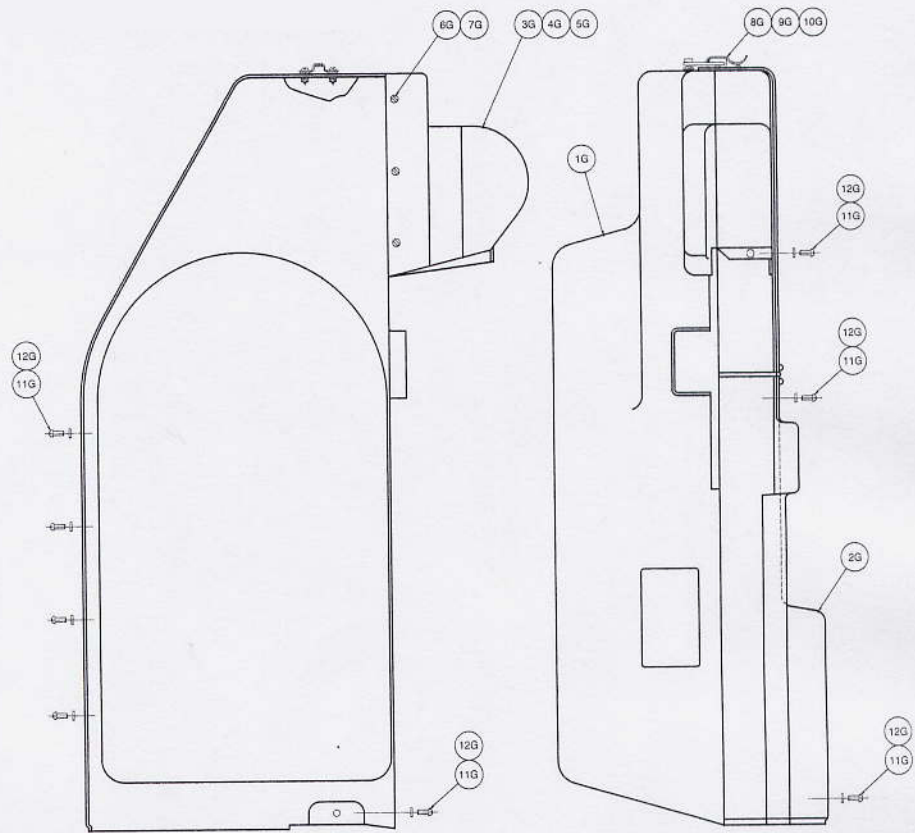



1	HEAD FOR ELECTRIC MACHINE
1A	HEAD FOR FOOT POWER OR STAND PN. MACH.
1B	HEAD FOR BENCH PNEUMATIC
2	STAND FOR ELECTRIC MACHINE
2A	STAND FOR FOOT POWER MACHINE
2B	STAND FOR STAND PNEUMATIC MACHINE
3	BOX
4	BOX SPACER
5	BOX STUD BEARING
6	CHUTE COVER
7	4 RIVETS FOR NO. 8
8	CHUTE COVER HINGE
9	OIL CUP (2)
10	SET SCREW FOR NO. 5
11	COTTER PINS
12	WASHER FOR NO. 92
13	PAWL PIN
14	PAWL SPRING
15	PAWL SPRING STUD
16	POCKET PLUNGER CAP
17	PIN FOR NO. 18
18	POCKET PLUNGER SPRING
19	4 SCREW FOR NO. 16
20	POCKET SPRING PIN
21	POCKET FASTENING SCREW
22	LOCKNUT FOR NO. 21
23	POCKET PLUNGER SPRING PIN
24	POCKET PLUNGER
26	OIL CUP
27	SPLIT END COLLAR
27A	LOCKSCREW FOR NO. 27
28	MAIN SHAFT
29	FASTENING SCREW FOR NO. 30 FOR FISHER
30	CLUTCH KEY CLUTCH ONLY
31	FLYWHEEL
31A	2 BUSHINGS FOR NO. 31
32	CABLE FOR NO. 117 & CLUTCH SOLENOID
33	BELT
34	CABLE CONNECTOR (3)
35	2 FASTENING SCREWS FOR NO. 39
36	2 LOCKNUTS FOR NO. 35
37	RUNNING LIGHT
38	BRACKET FOR NO. 39
39	MAIN SWITCH
40	CABLE CONNECTOR FOR NO. 44
41	MOTOR PULLEY
42	LOCKSCREW FOR NO. 41
43	CABLE FOR NO'S 39 & 125
44	POWER CORD
45	BOX SPRING
46	BOX NUT
47	BOX STUD FOR POWER MACHINES

47A	BOX STUD FOR FOOT POWER MACHINE
48	SPACER FOR NO'S 3 & 63
49	SPACER FOR NO'S 1 , 1B & 63
50	PLUNGER GOLD AS
51	LINK - UNIT
52	RIVET
53	LOCKNUT FOR NO. 54
54	LOCKSCREW
55	LOCKNUT
56	DRIVING STEM
58	POCKETS
59	ANVIL LOCKSCREW
60	LOCKNUT FOR NO. 61
61	ANVIL ADJUSTING SCREW
62	2 HEAD FASTENING SCREWS FOR ELECTRIC MACH.
62A	2 HEAD FASTENING SCREWS FOR STAND PN. & P.P. MACH.
63	BOX CARRIER ROADWAY
64	RATCHET
65	COTTER PIN (3)
66	HEAD LEVER PLUNGER LINK PIN
67	HEAD LEVER FOR ELECTRIC & PN. MACHINES
67A	HEAD LEVER FOR FOOT POWER MACH.
68	2 POCKET PLUNGER ADJUSTING SCREWS
69	2 LOCKNUTS FOR NO. 68
70	CUT-OFF LINK
71	CARRIER FASTENING SCREW
72	CUT-OFF SCREW
73	CUT-OFF
74	CUT-OFF RIVET
75	SOLID ANVIL
76	RECEDING SPINDLE
77	RECEDING SPINDLE ANVIL
78	RECEDING SPINDLE SPRING
79	RECEDING SPINDLE ANVIL SCREW
80	STEEL ARM
81	PIN FOR NO. 80
82	2 DOWEL PINS FOR NO. 112
83	CABLE FOR NO'S 117 & 191
84	CABLE FOR NO'S 39 & 117
85	CABLE CONNECTOR
86	CABLE CONNECTOR
87	FASTENING SCREW FOR NO'S 2, 38 & 122
88	WASHER FOR NO. 87
89	2 ROLL PINS FOR NO'S 2 & 90
90	MOTOR BRACKET
91	CABLE FOR NO'S 39 & 125
92	RATCHET PAWL
93	INTERMEDIATE LINK
94	PIN (2)
95	INTERMEDIATE LEVER FOR ELECTRIC & PN. MACH.

95A	INTERMEDIATE LEVER FOR FOOT POWER MACHINE
96	PIN
97	SPACERS
98	MOUNTING BRACKET FOR NO. 191
99	2 FASTENING SCREWS FOR NO. 98
100	2 LOCKWASHERS FOR NO. 101
101	2 NUTS FOR NO. 99
102	CONNECTING ROD FOR ELECTRIC MACHINE
102A	CONNECTING ROD FOR NO'S 95A & 138
103	2 FASTENING SCREWS FOR NO. 98
104	CABLE CONNECTOR FOR NO. 191
105	POWER LINK STUD
106	LOCKSCREW FOR NO. 105
106A	LOCKSCREW
107	OIL CUP
108	POWER LINK
109	PIN FOR NO'S 28 & 108
110	2 FASTENING SCREWS FOR CLUTCH MOUNTING PLATE
111	2 LOCKWASHERS FOR NO. 110
112	POWER BRACKET
113	FASTENING SCREW FOR NO. 115
114	LOCKWASHER FOR NO. 113
115	UPPER BRACKET (SOLD AS UNIT WITH NO'S 122 & 123)
116	CABLE FOR NO. 117 & CLUTCH SOLENOID
117	CONTROL BOX
118	CABLE CONNECTOR
119	TIME DELAY RELAY
120	SCREW FOR NO'S 117&119
121	LOCKNUT FOR NO. 120
122	LOWER BRACKET (SOLD AS UNIT WITH NO'S 115 & 123)
123	BACK BRACKET (SOLD AS UNIT WITH NO'S 115 & 122)
124	2 FASTENING SCREWS FOR NO. 117
124A	2 LOCKNUTS FOR NO. 124
125	MOTOR
126	4 FASTENING SCREWS FOR NO. 125
127	4 WASHERS FOR NO. 126
128	CABLE FOR NO'S 131 & 191 (ELECTRIC MACH.)
129	CABLE CONNECTOR FOR NO'S 131 & 128
130	GUARD FOR NO'S 131 OR 183
131	FOOT SWITCH ELECTRIC
132	2 SCREWS WITH LOCKWASHERS FOR NO'S 131 OR 183
133	4 SCREWS FOR NO. 130
134	3 SCREWS FOR NO. 135
135	FOOT TREADLE GUARD
136	LOCKNUT (2)
137	TREADLE ADJUSTING SCREW
138	TREADLE

139	2 LOCKNUTS FOR NO. 141
140	4 PINS
141	2 BOLTS FOR NO'S 2, 2A OR 2B
142	TREADLE STOP SCREW
143	TREADLE SPRING
144	PIN (2)
145	PIN FOR NO. 138
146	SPACERS FOR NO, 138
147	2 LOCKSCREWS FOR NO. 148
148	2 SET SCREWS FOR NO. 149
149	INTERMEDIATE LEVER FULCRUM PIN
150	PAWL STUD WASHER
151	PAWL STUD
152	COTTER PIN FOR NO. 151
153	CLAMP SCREW FOR NO'S 149 & 156
154	SET SCREW FOR NO. 151
155	PAWL SPRING
156	PAWL LEVER
157	LOWER PAWL
158	UPPER PAWL
159	CYLINDER CONNECTING ROD (STAND PN, MACH.)
160	LOCKNUT FOR NO'S 159 & 169
161	ADJUSTING SCREW (2) WITH NO. 163
162	LOCKNUT FOR NO. 161 (2)
163	MUFFLER (2) WITH NO. 161
164	HEXAGON NIPPLE (2)
165	QUICK EXHAUST VALVE (2)
166	ELBOW (3)
167	UPPER HOSE FOR NO. 169
168	LOWER HOSE FOR NO. 169
169	AIR CYLINDER FOR STAND PNEUMATIC MACHINE
170	PRESSURE REGULATOR WITH NO. 172
171	LOCKNUT FOR NO. 170
172	GAUGE WITH NO. 170
173	AIR FILTER
174	AIR LUBRICATOR
175	SUPPLY HOSE
176	FIL.-REG.-LUB.-GAUGE BRACKET
177	2 SCREWS FOR NO. 176
178	2 LOCKWASHERS
179	BRACKET FOR NO. 176
180	2 SCREWS FOR NO. 179
181	2 LOCKWASHERS FOR NO. 180
182	HOSE FOR NO'S 174 & 183
183	FOOT VALVE (4-WAY PNEUMATIC)
184	HEXAGON NIPPLE (3)
185	LOCKSCREW (3)
186	PIN FOR NO. 188(2)
187	SPACERS
188	AIR CYLINDER BRACKET
189	PIN FOR NO'S 169& 188
190	2 SPACERS FOR NO'S 98 & 191



191	PROTECTOSWITCH
192	PROBE
193	ELECTRICAL BOX
193A	BRACKET FOR NO. 193
194	COVER WITH 2 SCREWS FOR NO. 193
195	MAIN SWITCH
196	2 FASTENING SCREWS FOR NO. 193
197	CABLE FOR NO'S 131 & 191 (BENCH PN. MACH.)
198	2 FASTENING SCREWS FOR NO'S 98 & 192
199	2 LOCKWASHERS FOR NO. 198
200	CABLE FOR NO'S 191 & 193
201	CABLE FOR NO'S 193 & 204
202	REDUCER FOR NO'S 166 & 203 (2)
203	AIR CYLINDER FOR BENCH PNEUMATIC
204	4-WAY SOLENOID VALVE
205	UPPER HOSE FOR NO'S 203 & 204
206	LOWER HOSE FOR NO'S 203 & 204
207	HOSE FOR NO'S 174 & 204
208	ELBOW (ROD FLAT)
209	MUFFLER (2)
210	3 FASTENING SCREWS FOR NO. 204
211	3 LOCKWASHERS FOR NO. 210
212	CABLE CONNECTOR FOR NO'S 44 & 193
213	2 FASTENING SCREWS FOR NO. 98
214	2 LOCKWASHERS FOR NO. 213
215	2 SPACERS FOR NO'S 98 & 191
216	CYLINDER HOLDER

217	LOCKWASHER FOR NO. 218
218	NUT FOR NO. 216
219	CYLINDER BRACKET
220	LOCKNUT FOR NO'S 203 & 221
221	CYLINDER CONNECTING ROD
222	UPPER HOSE FOR BENCH PNEUMATIC' -
223	LOWER HOSE FOR BENCH PNEUMATIC
224	HOSE FOR NO'S 174& 183
225	2 COTTER PINS FOR NO. 226
226	PIN FOR NO. 203
227	PLUNGER UNIT FOR NO. 234
228	POCKET CAP FOR NO. 229
229	POCKET HOLDER
230	POCKET SPRING PIN
231	POCKET FASTENING SCREW
232	POCKETS
233	SPINDLE SPRING
234	TOP SET SPINDLE
235	TOP SET
236	PLUNGER UNIT FOR NO. 237
237	STOP PIN
238	SPINDLE STOP
239	CLAMPING SCREW FOR NO. 238
240	TOP SET SPINDLE FOR NO. 238